

PRODUCT SPECIFICATIONS

Product name	SCOPEMAN MSX-500Di
Camera	1/1.8" interline CCD image sensor, 2.11 megapixel total
Number of effective pixels	2.01 megapixel
Scanning method	Interlace
Magnification	∞ to 500x calculated with *14" monitor magnification
Light source	27 high luminance white LEDs; Light up switch/light adjustment function
LCD monitor	3.5" TFT color LCD (LED backlight)
Interface	USB Ver1.1 Mass storage/based on USB Video Class *Compatible with Windows® XP SP2 or higher (Recommended PC/CPU: Pentium 4 or higher, memory: 512 MB or higher)
Recordable media	SD card
Recordable formats	BMP/JPEG (still image)
Software	Measurements between 2 points; angle; area (all manual measurements)
Temperature range	5°C to 40°C
Power	AC Adapter; AC100 – 250V; DC12V; 3A
Optional	Lithium ion battery; Light permeation unit; External freeze switch
Unit size (mm)	164.20mm (width) x 220.72mm (height) x 181mm (depth)
Weight	Approximately 2.1kg (including AC adapter)
Accessories	SD card; USB cable; Video cord; AC adapter; Software CD-ROM; User manual

● Microsoft, Windows® is a registered trademark of Microsoft Corporation of America and other countries.

MAGNIFICATION OF EXTERNAL OUTPUT

Magnification is as follows if a monitor other than a 14" monitor is used.

	13"	14"	20"
0.93	1	1.43	
9.29	10	14.3	
18.6	20	28.6	
46.4	50	71.4	
92.9	100	143	
186	200	286	
279	300	429	
371	400	571	
464	500	714	

WD/FIELD OF VIEW

Magnification	WD (mm)	Field of View (mm)
1x	460.1	284.059 x 213.921
10x	53.5	28.406 x 21.392
20x	30.9	14.203 x 10.696
50x	17.3	5.681 x 4.278
100x	12.8	2.841 x 2.139
200x	10.6	1.420 x 1.070
300x	9.8	0.947 x 0.713
400x	9.4	0.710 x 0.535
500x	9.2	0.568 x 0.428

OPTIONAL

- DC 7.2V Lithium ion battery pack
- Light permeation unit
- External freeze switch

FIGURE (mm)

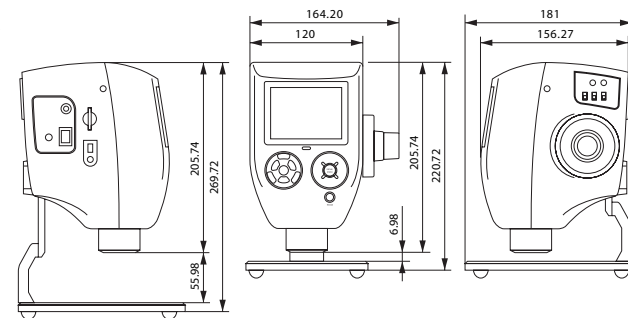

IMAGE MEASUREMENT SOFTWARE

Specifications and design may be improved or changed without notice.



STR - Science Technology Resources

5274 Scotts Valley Dr. #204, Scotts Valley, CA 95066, U.S.A.
 Phone 877-395-1001 Fax 866-991-9591
 Website: www.strscopes.com
 Email: sales@strscopes.com

• Please direct inquiries to the contacts stated below.

MSX-500Di

An integrated unit with a small, lightweight, 2.11 megapixel digital CCD microscope.

3.5 inch TFT



2 Megapixel CCD

It's NEW



All your imaging requirements in a single, compact body.

A small, lightweight, 2.11 megapixel digital CCD microscope

MSX-500Di

The MSX-500Di digital microscope, with its 2 megapixel CCD camera, features an integrated 3.5" LCD monitor and is a stand alone unit for inspection and saving images. The USB connection allows for image previews as well as camera control and file transfers (for mass storage) with a PC. Lens magnification is ∞ to 500× like the INF-500 Series (magnification calculated on a 14" monitor). Illumination for the unit is in the form of 27 LEDs, which are separated into 7 blocks that can be switched as desired. This allows for optimum lighting for the subject.

Easy operation

● Operation is so simple

- Screen that instantly displays the current settings
- Digital display of magnification information and auto-scaling.

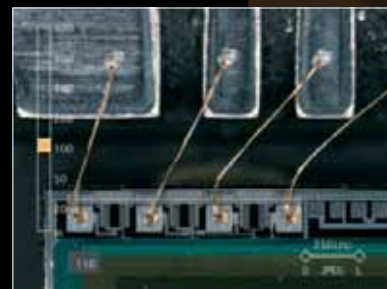
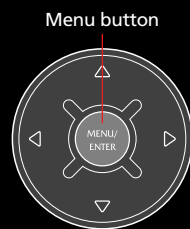

Picture view

● Playback of recorded images

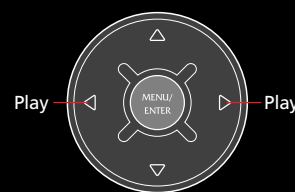

Recorded images can be shown on the display. Each push of the ▶ button will display the next new image, while each push of the ◀ button will display the next old image.



LED Illumination

● Free control of illumination

LED illumination can be turned ON/OFF for each block as desired.

Illumination for the unit is in the form of 27 LED lights, which provides the most optimum lighting for each piece of work. Illumination is separated into 7 blocks and can be switched as desired, allowing clear observation of the work.

LED illumination switch

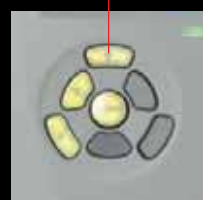

The switch lights up the corresponding section of the LED.

Example

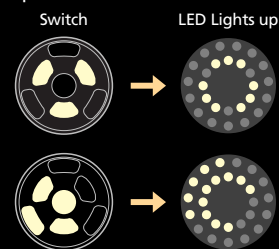

Example of photography



■ CCD camera bonding



■ Circuit board



■ Welds on a molded item



■ Granulated sugar



■ Plants



■ Capillary vessels in the finger

2megapixel CCD

● Features a 2 megapixel CCD camera

Features a high performance 2.11 megapixel CCD camera. Even the finest of details can be imaged clearly.

TFT LCD monitor

● Features an integrated 3.5" LCD monitor

The 3.5" LCD monitor is integrated within the unit to allow standalone imaging and saving of images.

Camera control

● The camera can be controlled from a computer

The camera can be controlled (preview function) via the USB connection as well as for file transfers (mass storage function) (available only with Windows XP SP2).



Illumination adjustment volume knob

AE volume knob

Adjustment switch



Video output terminal

SD card slot

Mini USB terminal

External FREEZE input terminal (optional)

Power switch

Flash memory slot

● SD card slot available as standard

Highly accurate images can be saved using the SD card slot within the unit. (BMP/JPEG)



Storage size for each image

Symbol	SD card	JPEG	BMP
S	640 × 480	Approx. 130KB	Approx. 900KB
M1	800 × 600	Approx. 190KB	Approx. 1400KB
M2	1280 × 960	Approx. 440KB	Approx. 3600KB
L	1600 × 1200	Approx. 730KB	Approx. 5600KB

The size differs slightly for each image.